



Single Family

Plan 3018 Junction

This home includes a home office, dual primary closets, and spa-style bath for comfort and luxury. A large family room, formal dining, and covered porch and patio make it perfect for entertaining or relaxing. At Junction, enjoy a welcoming community and convenient access to everyday needs.

For more details or to express interest, contact us today!

Priced From
\$714,900

1 Elevation Available

 **4** Bedrooms

 **3.5** Bathrooms

 **3,018+** Sq. Ft.

 **2** Car Garage



All square footage is approximate. Renderings are artist's conceptions and may vary slightly from the actual home. Homes may be built in reverse of plans shown, depending on site conditions. Minor architectural changes may be made occasionally at the option of the builder. Please contact your Sales Consultant for details.

Elevation 3018 A

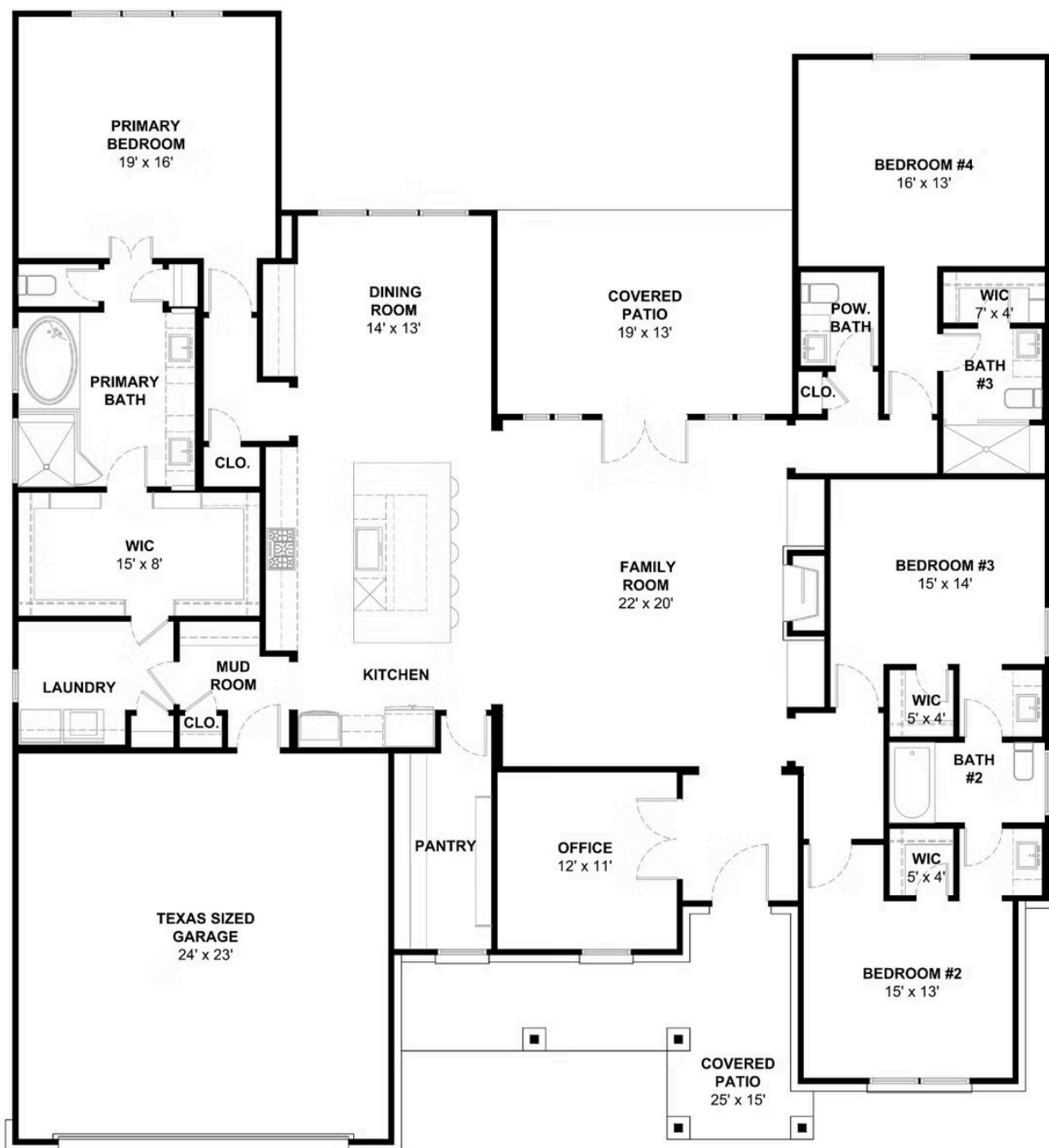

All square footage is approximate. Renderings are artist's conceptions and may vary slightly from the actual home. Homes may be built in reverse of plans shown, depending on site conditions. Minor architectural changes may be made occasionally at the option of the builder. Please contact your Sales Consultant for details.

Elevation 3018 A Options

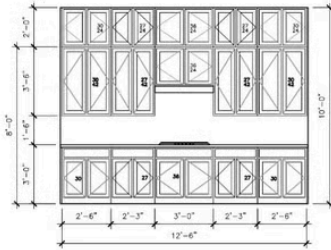

A KITCHEN (OPTION)

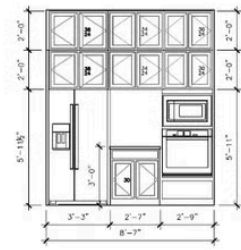

B KITCHEN (OPTION)

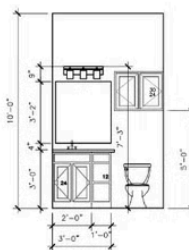

C BATH #2 (OPTION)

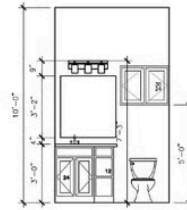

D POWDER BATH (OPTION)

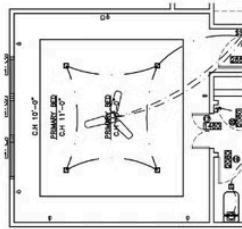

E PRIMARY BATH (OPTION)

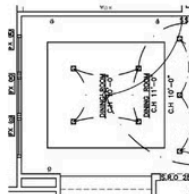

F DINING ROOM (OPTION)

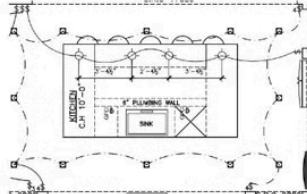

G KITCHEN PENDANT (OPTION)

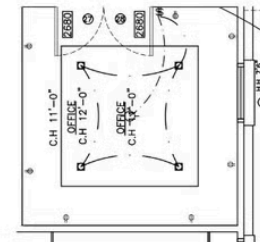

H OFFICE (OPTION)

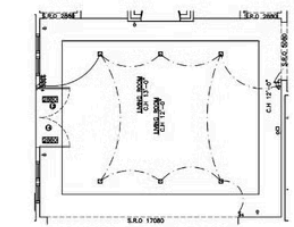

I LIVING ROOM TRAY (OPTION)

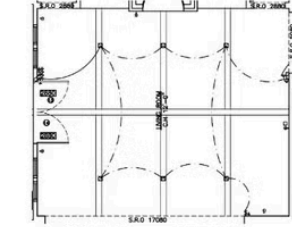

J LIVING ROOM BEAMS (OPTION)

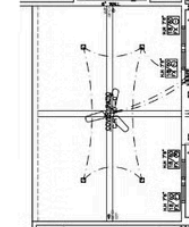

K COVER PATIO (OPTION)

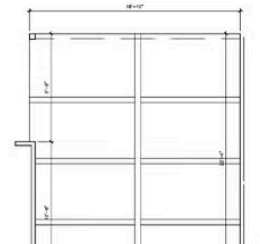

L COVER PATIO (OPTION)

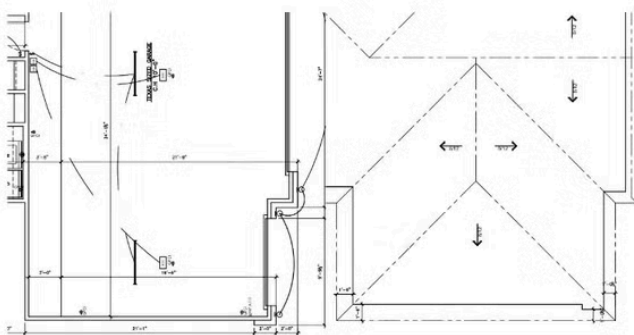

M 3 CAR GARAGE (OPTION)



All square footage is approximate. Renderings are artist's conceptions and may vary slightly from the actual home. Homes may be built in reverse of plans shown, depending on site conditions. Minor architectural changes may be made occasionally at the option of the builder. Please contact your Sales Consultant for details.